

Model 66

10" Tilting Arbor Saw

MAINTENANCE INSTRUCTIONS AND PARTS LIST

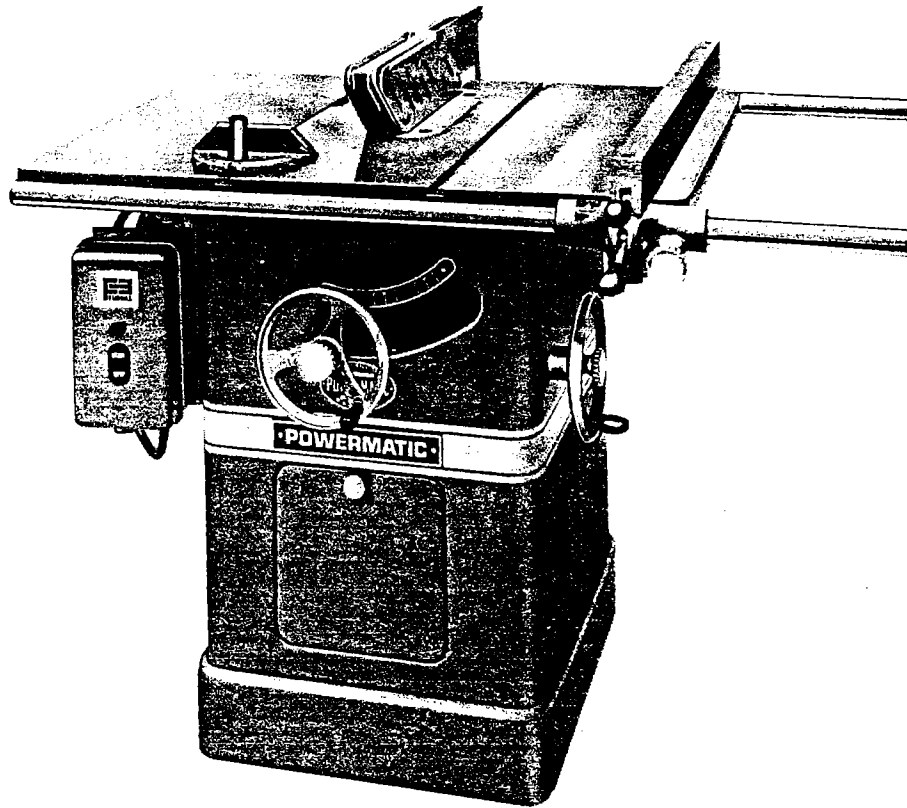

POWERMATIC®

Strength and performance right down the line.

POWERMATIC  OUDAILLE, INC.

McMinville, Tennessee 37110

AC 615-473-5551

FORWARD

SAFETY FIRST

This manual has been prepared for the owner and those responsible for the maintenance of a Powermatic Model 66 Table Saw. Its purpose, aside from machine operation, is to promote safety through the use of accepted operating practice. Read the safety and operating instructions thoroughly before operating the machine.

In order to obtain maximum life and efficiency from your Powermatic Table Saw, follow all the instructions in the Operating Instructions and Maintenance Manuals carefully.

The specifications put forth in this manual were in effect at the time of publication. However, owing to Powermatic's policy of continuous improvement, changes to these specifications may be made at any time without obligation on the part of Powermatic Houdaille, Inc.

WARRANTY

This machine and its component parts have been carefully inspected at various stages of production and each finished machine is subjected to a final inspection before shipment. We agree that for a period of eighteen (18) months from date of delivery from our authorized dealer to replace, at our option, any machine (or component part thereof) proving defective within the above period, F.O.B. our plant providing such machine (or component part) is returned pre-paid to our plant, or a designated service center of the undersigned, for our examination. **THIS WARRANTY DOES NOT INCLUDE REPAIR OR REPLACEMENT REQUIRED BECAUSE OF MISUSE, ABUSE, OR BECAUSE OF NORMAL WEAR AND TEAR; OR ELECTRICAL MOTORS WHICH ARE WARRANTED BY THEIR MANUFACTURER AND WHICH SHOULD BE TAKEN TO THEIR LOCAL AUTHORIZED REPAIR STATION FOR SERVICE. FURTHER, WE CANNOT BE RESPONSIBLE FOR THE COST OF REPAIRS MADE OR ATTEMPTED OUTSIDE OF OUR FACTORY OR DESIGNATED SERVICE CENTER WITHOUT OUR AUTHORIZATION. NO CLAIMS FOR DEFECTS WILL BE HONORED IF SERIAL NUMBER PLATE HAS BEEN REMOVED. THIS WARRANTY IS MADE EXPRESSLY IN PLACE OF ALL OTHER WARRANTIES OR GUARANTEES, EXPRESS OR IMPLIED, WITH RESPECT TO FITNESS, MERCHANTABILITY, QUALITY OR OPERATIVENESS. THIS WARRANTY BECOMES EFFECTIVE ONLY WHEN THE ACCOMPANYING CARD IS FULLY AND PROPERLY FILLED OUT AND RETURNED TO THE FACTORY WITHIN TEN (10) DAYS FROM DATE OF DELIVERY.**

SAFETY INSTRUCTIONS

1. Read, Understand & Follow the safety and operating instructions found in this manual. Know the limitations and hazards associated with this table saw. A Safety Rules decal is installed on each machine to serve as a reminder of basic safety practice.
2. Grounding of the Table Saw: Make certain that the machine frame is electrically grounded and that a ground lead is included in the incoming electrical service. In cases where a cord and plug are used, make certain that the grounding plug connects to a suitable ground. Follow the grounding procedure indicated in the National Electric Code.
3. Eye Safety: Wear an approved safety shield, goggles, or glasses to protect eyes when operating the table saw.
4. Personal Protection: Before operating the machine, remove tie, rings, watch and other jewelry and roll up sleeves above the elbows. Remove all loose clothing and confine long hair. Protective type footwear should be used. Where the noise exceeds the level of exposure allowed in Section 1910.95 of the OSHA Regulations use hearing protection devices. Do not wear gloves.
5. Work Area: Keep the floor around the machine clean and free of scrap material, saw dust, oil and grease to minimize the danger of tripping or slipping. Be sure the table is free of all scrap, foreign material and tools before starting to cut. Powermatic recommends the use of anti-skid floor strips on the floor area where the operator normally stands and that each machine's work area be marked off. Make certain the work area is well lighted and that a proper exhaust system is used to minimize dust. Provide adequate work space around the machine.
6. Guards: Keep the machine guards in place for every operation on which they can be used. If any guards are removed for maintenance, Do Not Operate The Machine until the guards are reinstalled.
7. Alignment: Check the alignment of the splitter, fence and miter slot to the blade before using the table saw. Note: A caution decal is installed on each guard and splitter to warn against the hazards of misalignment. (Use the maintenance manual for instructions on alignment).
8. Maintain tools in top condition: Check the saw blade or cutter for cracks or missing teeth. Do not use a cracked or dull blade or one with missing teeth or improper set. Make sure the blade or cutter is securely locked on the arbor.
9. Operator position: Do not stand in line with the saw blade or work piece and do not allow anyone else to do so. Never climb on or near the saw.
10. Hand Safety: Keep hands clear of the blade area. Do not reach past the blade to clear parts or scrap with the saw blade running. Never saw free hand. Avoid awkward operations and hand positions where a sudden slip could cause your hand to contact the blade.
11. Safety Devices: Always use the splitter, blade guard, push stick and other safety devices for all operations where they can be used. On operations such as dadoing or molding where such devices may not be used, use feather boards, (see Pg. 12) fixtures and other safety devices and use extreme caution. Re-install the splitter and blade guard immediately after completing the operation that required their removal.
12. Do Not Overreach: Maintain a balanced stance and keep your body under control at all times. Do not overreach. Use a support table or have a helper or "tailman" take stock away from the back side of the blade.
13. Saw Blade Rotation: Be sure the saw blade rotates clockwise when viewed from the motor side (leftside) of the machine.
14. Adjustments: Make all adjustments to the machine and operational set-up with the power off. Never remove the insert with the blade running.

15. Material Condition: Do not attempt to saw boards with loose knots or with nails or other foreign material on its surface. Do not attempt to saw twisted, warped, bowed or "in wind" stock unless one edge has been jointed for guiding purposes prior to sawing.

16. Large Stock: Do not attempt to saw long or wide boards unsupported where spring or weight could cause the board to shift position.

17. Machine Stability: Bolt the machine to the floor through the lag holes provided to avoid any tendency of the saw to tip or shift during cutting operations.

18. Careless Acts: Give the work you are doing your undivided attention. Looking around, carrying on a conversation, and "horseplay" are careless acts that can result in serious injury.

19. Job Completion: If the operator leaves the machine area for any reason, he should turn "off" the power to the table saw motor and wait until the saw blade comes to a complete stop before his departure. In addition, if the operation is complete, he should clean the table saw and the work area. NEVER clean off the table saw with power "on" and NEVER use the hands to clear sawdust and debris; use a brush.

20. Disconnect Machine: Before performing any service or maintenance or when changing blades. Note: A machine under repair should be Red Taged to show it should not be used until the maintenance is complete.

21. Replacement parts: Use only Powermatic or factory authorized replacement parts and accessories; otherwise the table saw warranty and guarantee is null and void.

22. Misuse: Do not use this Powermatic table saw for other than its intended use. If used for other purposes, Powermatic disclaims any real or implied warranty and holds itself harmless for any injury which may result from that use. Do not equip this table saw with a motor larger than three (3) horsepower at 3600 RPM. Doing so voids the warranty and Powermatic holds itself harmless from any injury that may result.

SPECIFICATIONS

Table with standard extensions

28" x 38"

Rip Fence	1-1/2" x 2-1/2" x 33"	Maximum width cutoff in front of saw in 3-1/8" stock.	12-1/4"
Arbor diameter	5/8"	Maximum width of dado cut.	13/16"
Saw Blade diameter	10"	Maximum motor.	3 HP, 3600 RPM.
Blade tilt maximum	45°	Maximum speed of 10" saw blade.	11000 SFM.
Maximum depth of cut	90° : 3-1/8" 45° : 2-1/8"	Table height to floor. Net wt. with motor.	34" 450 lbs.
Maximum cut with standard extensions to the right of saw blade.	25"	Shipping wt. with motor.	500 lbs.
Maximum width of cutoff in front of saw in 1" stock.	15"		

NOTE: The above specifications were current at the time that this manual was published, but because of our policy of continuous improvement, Powermatic Houdaille, Inc., reserves the right to change specifications without notice and without incurring obligations.

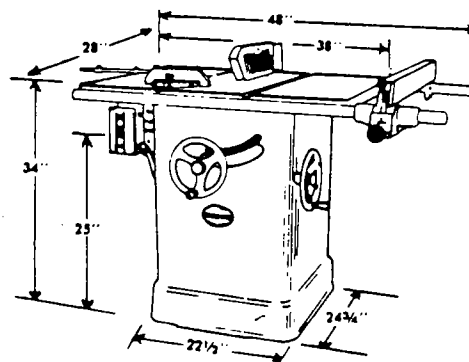

MODEL 66—10" T. A. SAW

MACHINE INSTALLATION ADJUSTMENTS AND MAINTENANCE

RECEIVING:

Remove saw from shipping container and check for damage. Report any damage to your distributor immediately. Accessories and rails were shipped in separate cartons. Clean protective coating from the table, extensions and fence. Read the instruction manual thoroughly for assembly, alignment, maintenance and safety instructions.

INSTALLATION:

Mount machine on a solid foundation and lag to the floor through the four lag screw holes provided in the machine base. Mount table extensions, leveling them to the table using a straight edge so that they form a flat plane with the table top. Install the front (graduated) and rear rails with the hardware provided. Slide the fence and carriage assembly on the mounting rails. Mount the splitter and guard assembly. Install the miter gauge in its left-hand slot.

MITER SLOT ALIGNMENT:

To check the alignment of the miter slot to the blade, raise the blade at its 0° (90°) position to its maximum height. Mark one tooth with a grease pencil and position the tooth slightly above the top edge of the table at the front. Raise the miter gauge bar slightly out of its slot to serve as a shoulder. Using a combination square against the side of the bar, slide the scale over until it touches the tip of the blade and lock in position (Fig. 1). Rotate the marked tooth so that it is slightly above the table top at the rear and using the square as in front, check whether the distance to the blade is the same. If it is not, loosen the three (3) mounting screw that lock the table to the cabinet and move the table to bring the miter slot in line with the blade. The blade should be kept centered with the slot in the table insert to insure clearance at both the 90° and 45° positions. After aligning, lock the table to the cabinet by retightening the three mounting screws.

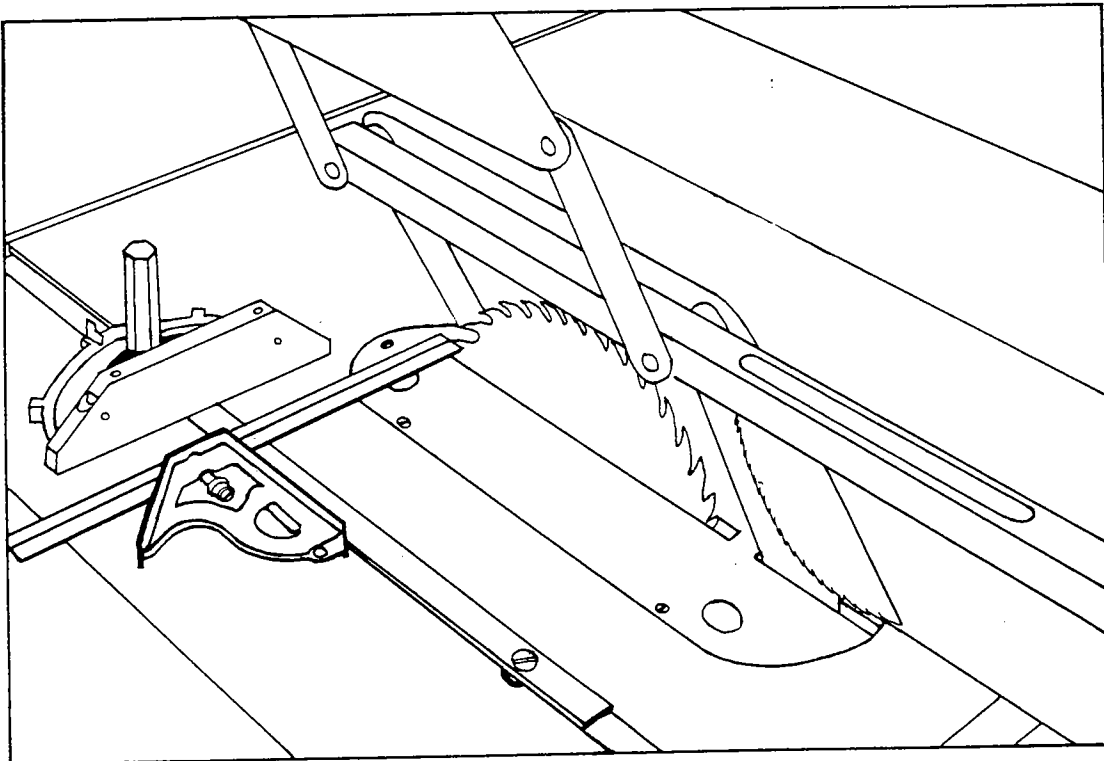

Miter Slot Alignment (Fig. 1)

TILT STOP ADJUSTMENT:

Using a combination square, check the 90° (0) and 45° stops as shown in Fig. 2. Adjust stop positions if required, using the stop screws as shown. Check the pointer at 90° (0) and readjust if required.

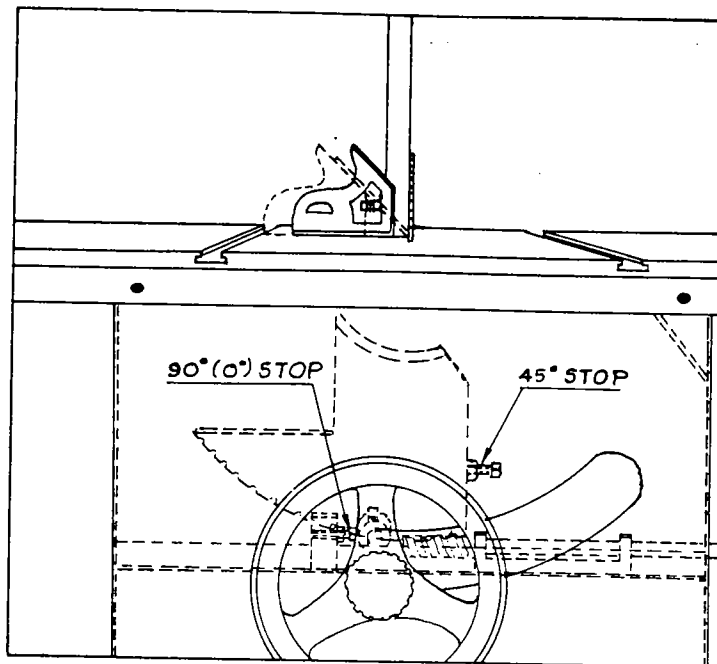

Tilting Stop Adjustment (Fig. 2)

FENCE ALIGNMENT:

In aligning the fence, the first step is to adjust the clamps. Using the lower clamp handle, check whether it locks the fence solidly in front. If it does not, adjust the locking action with the adjusting screw as shown in Fig. 3. With the front lock clamped, clamp the rear of the fence with the upper locking handle. Adjust as required by using the adjusting screw shown in Fig. 3 to obtain a good clamping action. Move the fence so that it is in line at the front with the right-hand edge of the right-hand miter gauge slot and lock the front clamp. The position at the rear of the table should be $1/64''$ to $1/32''$ to the right of the edge of the miter slot. Readjust if necessary by loosening top screw and adjusting the right and left jackscrew with a $3/8''$ allen wrench as shown in Fig. 4. To move the rear of the fence to the right, turn the right-hand setscrew counter-clockwise and the left-hand screw clockwise. After adjustment lock the fence mounting screw securely and wedge the setscrews tightly against the fence.

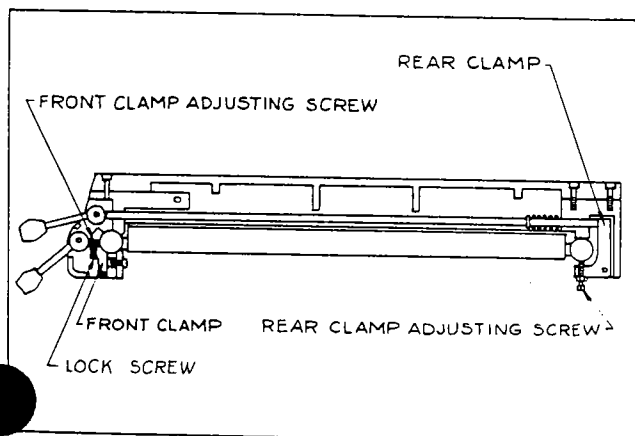

Fence Clamp Adjustment (Fig. 3)

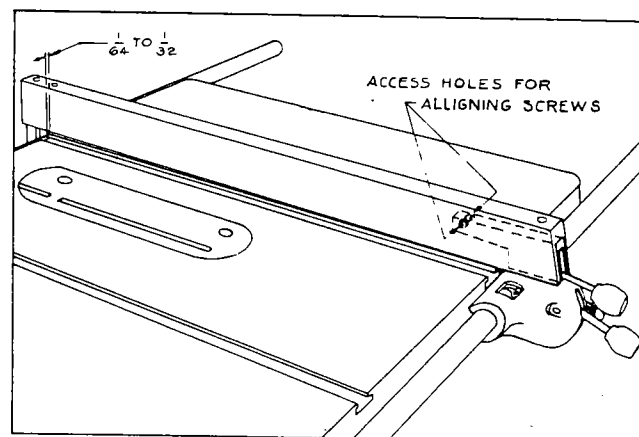

Fence Alignment (Fig. 4)

MITER GAUGE ADJUSTMENT:

If accurate crosscutting work is to be done using the miter gauge, check its squareness to the slot with a machinists square and readjust the stop position as required as shown in Fig. 5.

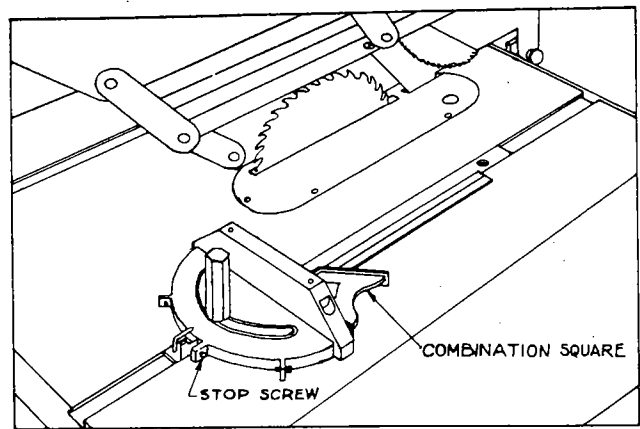

Miter Gauge Alignment (Fig. 5)

BELT TENSIONING:

The saw is equipped with a set of three matched belts and on replacement, replace the complete set. To retension the belts, loosen the cap screws on either side of the motor bracket as shown in Fig. 6, and pivot the motor and bracket to the right. Retighten the mounting screws. To remove and replace the belts, loosen the mounting screws and rotate the motor and bracket to the left as far as possible. Remove one belt at a time. After installing new belts, retension as indicated.

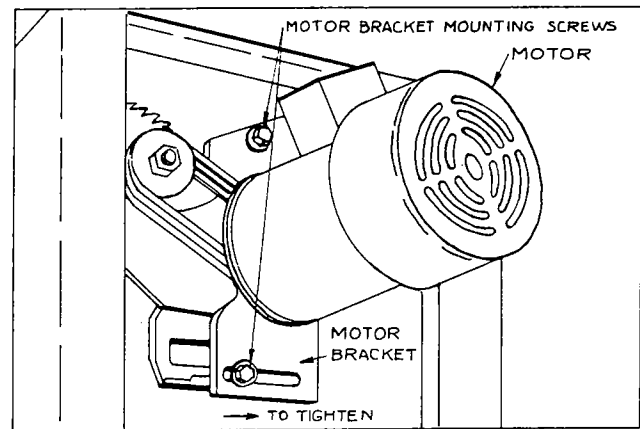

Belt Tensioning (Fig. 6)

ARBOR AND ARBOR BEARING REMOVAL:

To remove the saw arbor, remove the table top. Remove the lock nut, pulley and key. There is a 1/2" wrench flat on the end of the arbor to hold it while loosening the nut. Loosen the setscrew in the saw raising arm and the arbor; bearings and spacer will slide out of the arm housing (Fig. 7).

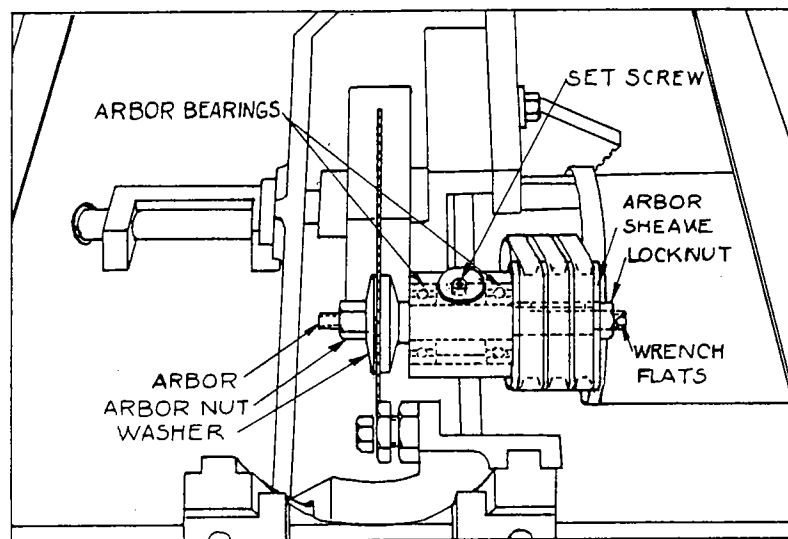

Arbor and Arbor Bearings (Fig. 7)

BLADE RAISING MECHANISM ADJUSTMENT:

If binding occurs, clean off all sawdust and pitch build-up and re-lubricate with a good non-hardening grease such as Fiske Company Lubriplate. If binding continues, check the fit-up of the worm and worm gear segment. The worm must be centered with the worm gear segment. If it is not centered, loosen the saw raising arm setscrews and move the arm as required (Fig. 8) and relock. If saw arm has been relocated, the table may have to be realigned so as to provide clearance between the saw blade and table insert slot and the splitter will have to be realigned.

NOTE: The saw arm setscrew must be tight to avoid the possibility of movement which could cause the blade to hit the insert.

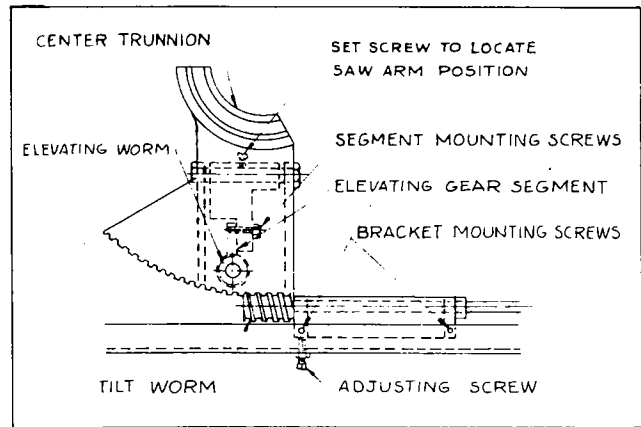

Worm and Segment Adjustments (Fig. 8)

SPLITTER ALIGNMENT:

One of the most critical adjustments to help avoid kickbacks is the splitter alignment. It should be checked and readjusted, if required after each blade change. To align the splitter to the blade use a combination square against the side of the raised up miter gauge bar and slide the scale against the top of the tooth. Check the splitter for parallelism to the miter slot and readjust if required, and for clearance. Move the miter gauge to the opposite side of the blade and using the combination square, slide the scale against the top of a tooth. Check for clearance. Clearance should be approximately equal on both sides of the blade (Fig. 9). The insert will have to be removed to get at the adjustment jackscrew mounted in the center trunnion.

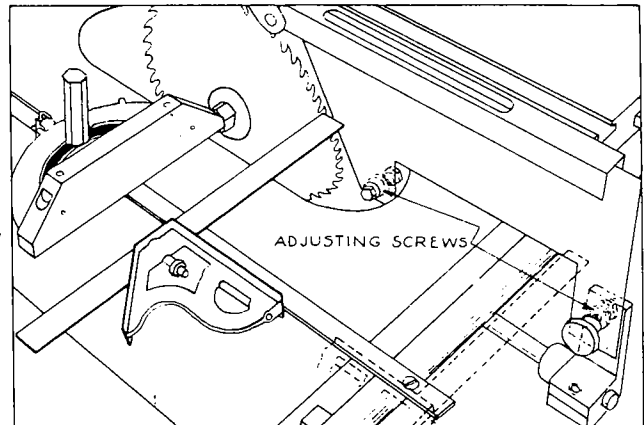

Splitter Adjustment (Fig. 9)

INSERT ADJUSTMENT:

Adjust the setscrews as required in the insert (Fig. 10) to insure that the insert is stable and flush with or slightly below the table top.

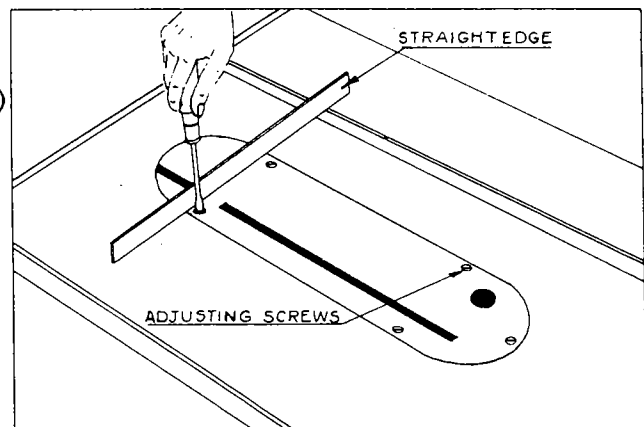

Insert Adjustment (Fig. 10)

CHANGING SAW BLADES:

To change a saw blade, disconnect machine from the power source. Remove the table insert. Place the arbor wrench on the arbor nut (note left-hand threads) and use a block of wood wedged between the saw blade and table. Remove the arbor nut and collar and saw blade. Install new blade making sure the cutting edge of the teeth at the top face toward the front of the saw. Slide the collar on the arbor and start the arbor nut on the threads. Snug the arbor nut against the collar and saw blade using the wrench and holding the saw blade with the thumb and finger tips. Wedge a block of wood between the saw blade and table and tighten the arbor nut securely. Replace the table insert and reconnect the machine to power source.

TITLING MECHANISM ADJUSTMENT:

If binding occurs in the tilting mechanism, clean off the sawdust and pitch accumulation and regrease. If binding continues, check the alignment and readjust as required to center of worm with the worm gear segment on the trunnion. If there is excessive play, loosen cap screws and adjust jackscrews (Fig. 8) clockwise to raise pinion. A tight mesh without binding is ideal. Retighten mounting screws and check over the 90° to 45° range of tilt for excessive play or binding. Readjust if required.

GENERAL MAINTENANCE:

Good saw operation requires periodic preventive maintenance. Keep the inside of the cabinet and trunnion area clean. A stiff brush will remove sawdust before it cakes and pitch or gum is easily removed with a commercial solvent or with a good oven cleaner. To accomplish this, remove the table by removing the three mounting screws and exposing the working mechanisms of the saw. After cleaning the tilting and raising worm and worm gear segments and the trunnions, grease these three areas with a good grade non-hardening grease such as Fiske Company "Lubriplate".

Check periodically for excessive end play in the tilting and raising mechanism and in the saw arbor and readjust as required.

Check periodically for belt tension and wear. Readjust or replace belt as required.

The table surface must be kept clean and free of rust for best results. Although some users prefer a wax coating, white talcum powder applied with a blackboard eraser rubbed in vigorously once a week will fill casting pores and form a moisture barrier. This method provides a table top that is slick and allows rust rings to be easily wiped from the surface. Important also is the fact that talcum powder will not stain wood or mar finishes as wax pickup does.

TROUBLE SHOOTING HINTS

TROUBLE	POSSIBLE CAUSE	REMEDY
Excessive vibration.	<ol style="list-style-type: none"> 1. Tilt or raising clamp knobs not tightened. 2. Blade out of balance. 3. Bad motor. 	<ol style="list-style-type: none"> 1. Tighten knobs. 2. Change blade. 3. Replace motor.
Cut out-of-square when crosscutting.	<ol style="list-style-type: none"> 1. Miter gauge out of adjustment. 2. Miter slot misaligned. 	<ol style="list-style-type: none"> 1. Reset stops and pointer. 2. Realign table.
Motor stalls or work piece binds or burns.	<ol style="list-style-type: none"> 1. Excessive feed. 2. Bad motor. 3. Dull or incorrect blade. 4. Miter slot misaligned. 5. Fence misalignment. 	<ol style="list-style-type: none"> 1. Reduce feed. 2. Replace motor. 3. Replace blade. 4. Realign miter slot. 5. Realign fence.
Cuts not true at 90° or 45°	<ol style="list-style-type: none"> 1. Stop screws not set properly. 	<ol style="list-style-type: none"> 1. Readjust stop screws.
Tilt or saw raising hand-wheels difficult to turn.	<ol style="list-style-type: none"> 1. Clamp knobs not released. 2. Worm and worm gear segment caked with sawdust and pitch. 3. Worm and worm gear segment out of alignment. 	<ol style="list-style-type: none"> 1. Unclamp. 2. Clean and regrease. 3. Realign worm and worm gear segment.
Motor overheats.	<ol style="list-style-type: none"> 1. Motor overloaded. 2. Improper cooling of motor. 	<ol style="list-style-type: none"> 1. Correct overload condition such as reducing the feed rate. 2. Clean sawdust from fan and duct areas of motor.
Motor starts slowly or fails to come up	<ol style="list-style-type: none"> 1. Low voltage. 2. Centrifugal switch not operating. 3. Bad motor. 	<ol style="list-style-type: none"> 1. Request voltage check from power company and correct low voltage condition. 2. Replace switch. 3. Replace motor.
Motor fails to develop full power.	<ol style="list-style-type: none"> 1. Power line overloaded. 2. Undersize wires in supply system. 3. Low voltage. 4. Bad motor. 	<ol style="list-style-type: none"> 1. Correct overload condition. 2. Increase supply wire size. 3. Request voltage check from power company and correct low voltage condition. 4. Replace motor.

STAND ASSEMBLY PARTS

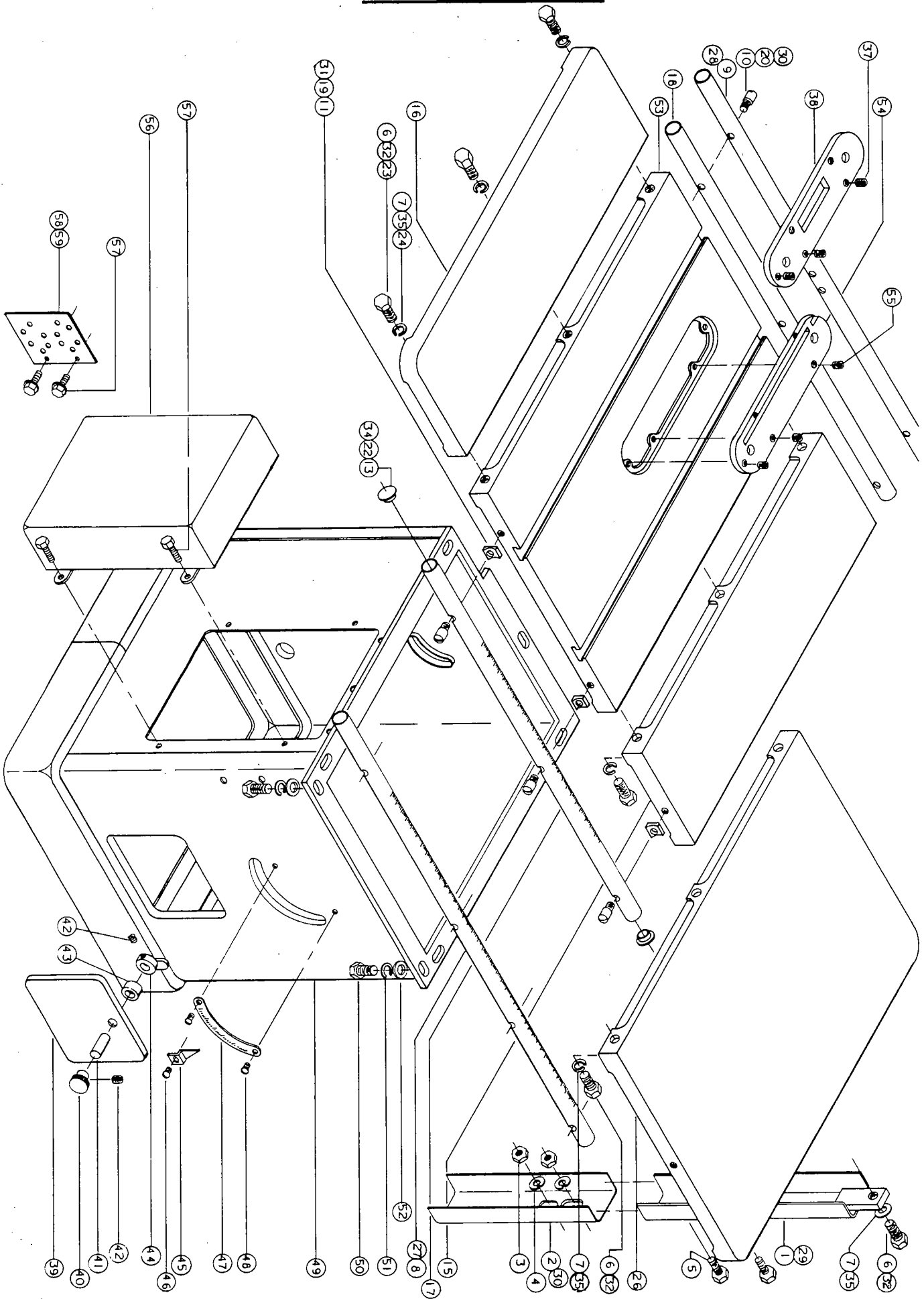

STAND ASSEMBLY PARTS

NO.	PART NO.	DESCRIPTION	QTY.
	2389003	EXT. KIT, 72" RAILS (ITEMS 1 THRU 15)	
	2423001	TABLE EXT. SUPPORT LEG ASSY. (ITEMS 1 THRU 7)	
1	2423006	INNER EXT. LEG ASSY.	1
2	3186009	OUTER LEG EXT.	1
3	6515001	HEX NUT, 5/16-18	2
4	6861200	LOCK WASHER, 5/16	8
5	6715036	HEX HD SCR, 5/16-18 x 5/8	2
6	6716031	HEX HD SCR, 3/8-16 x 1	11
7	6861300	LOCK WASHER, 3/8	8
8	3653012	FRONT RAIL, 72"	1
9	3653013	REAR RAIL, 72"	1
10	3058202	RAIL MTG. BOLT, 65-180	8
11	3735230	NYLON SPACER, 65-179	8
12	6050002	CLOTH BAG, 4-1/2 x 6 (NOT SHOWN)	1
13	6098006	BOTTOM PLUG, 1-1/8 CAPLUG	4
14	3186010	21" ROUND EXT. (NOT SHOWN)	1
15	3186011	21" SQUARE EXT.	1
	2389008	EXT. KIT, 48" RAILS W/8" STANDARD TABLE (ITEMS 16 THRU 25)	
16	3186008	8" STANDARD EXTENSION	2
17	3653010	48" FRONT RAIL	1
18	3653011	48" REAR RAIL	1
19	3735230	SPACER, NYLON 65-179	4
20	3058202	RAIL MTG. BOLT, 65-180	4
21	6050002	CLOTH BAG, 4-1/2 x 6 (NOT SHOWN)	1
22	6098006	BOTTOM PLUG, 1-1/8	4
23	6716031	HEX HD SCR, 3/8-16 x 1	6
24	6861300	LOCK WASHER, 3/8	6
25	6861200	LOCK WASHER, 5/16	6
	2389009	EXT. KIT, 72" RAILS & STEEL EXT. (ITEMS 26 THRU 36)	
26	2186005	STEEL EXTENSION	1
27	3653012	72" FRONT RAIL	1
28	3653013	72" REAR RAIL	1
29	2423001	SUPPORT TABLE LEG ASSY.	1
30	3058202	RAIL MTG. BOLT, 65-180	8
31	3735230	SPACER, NYLON 65-179	8
32	6716031	HEX HD SCR, 3/8-16 x 1	10
33	6050002	CLOTH BAG, 4-1/2 x 6 (NOT SHOWN)	1
34	6098006	BOTTOM PLUG, 1-1/8	4
35	6861300	LOCK WASHER, 3/8	10
36	6861200	LOCK WASHER, 5/16	6
	2328020	INSERT ASSY. (ITEMS 37 & 38)	
37	6714081	SLOTTED SET SCR, 1/4-20 x 3/8	5
38	3328026	TABLE INSERT	1
	2136002	DOOR ASSY. (ITEMS 39 THRU 44)	
39	3136018	DUST REMOVAL DOOR	1
40	3406005	SCREW ADJ KNOB (CHROME PLAT)	1
41	3703003	SHAFT	1
42	6714004	SOC SET SCR, 1/4-20 x 1/4	2
43	3735001	DOOR SPACER	1
44	3448002	LOCK	1
45	3604003	POINTER	1
46	6708045	RD HD MACH SCR, No. 8-32 x 3/8	1
47	3684232	PLATED TABLE ANGLE SCALE	1
48	6746001	PAN HD SELF TAPPING SCR, 6-32 x 1/4	2
49	2759036	STAND ASSY. (WELDMENT)	1
50	6716031	HEX HD CAP SCR, 3/8-16 x 1	3
51	6861300	LOCK WASHER, 3/8	3
52	6861301	FLAT WASHER, 3/8	3
53	3797044	TABLE	1
54	3328025	TABLE INSERT	1
55	6714081	SLOTTED HD SET SCR, 1/4-20 x 3/8	5
56	2104016	MOTOR COVER (WELDMENT)	1

NO.	PART NO.	DESCRIPTION	QTY.
57	6746023	HEX HD SELF TAPPING SCR, 1/4-20 x 5/8	6
58	3063276	SWITCH MTG BRKT	1
59	3063278	SWITCH MTG BRKT	1

TRUNNION ASSEMBLY PARTS

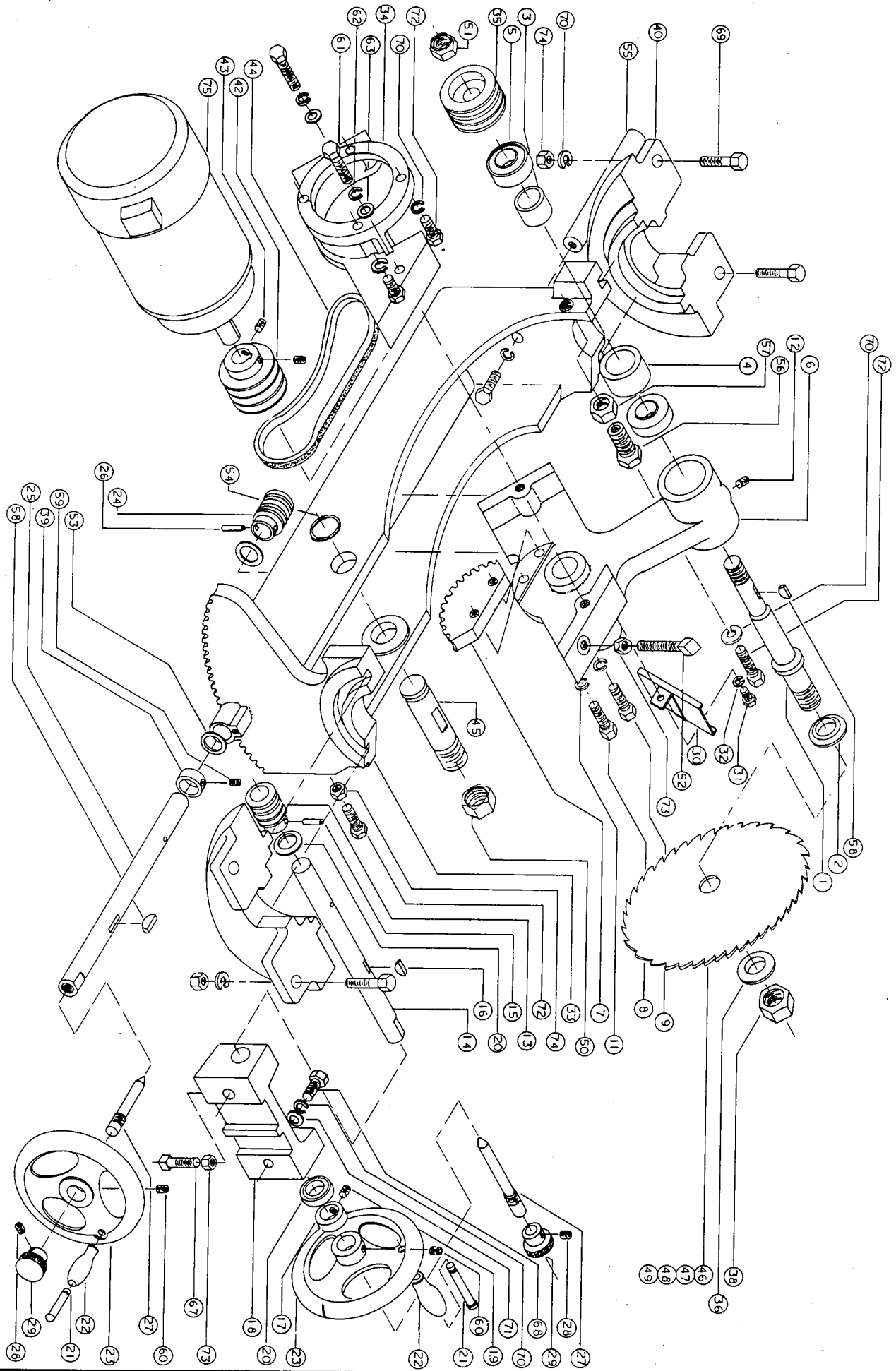

TRUNNION ASSEMBLY PARTS

NO.	PART NO.	DESCRIPTION	QTY.
	2025002	SAW RAISING BEARING ARM ASSY. (ITEMS 1 THRU 12)	
	2024008	COMPLETE ARBOR ASSY. (ITEMS 1 THRU 5)	
	2024001	ARBOR ASSY. (ITEMS 1 & 2)	
1	3700011	SAW ARBOR SHAFT	1
2	3838006	ARBOR SHAFT BEVEL WASHER	1
3	3737206	BEARING SPACER (OUTER)	1
4	3737207	BEARING SPACER (INNER)	1
5	6060008	BALL BEARING, FAFNIR W-204 PP	2
6	3025042	BEARING ARM	1
7	3237010	SEGMENT GEAR	1
8	6717018	HEX HD. CAP SCR., 7/16-14 x 1-1/2	1
9	6717019	HEX HD CAP SCR., 7/16-14 x 1-3/4	1
10	6861401	FLAT WASHER, 7/16 (NOT SHOWN)	2
11	6861400	LOCK WASHER, 7/16	2
12	6716009	CUP PT. SOC. SET SCR., 3/8-16 x 1/2	1
	2701001	SAW TILTING SHAFT ASSY. (ITEMS 13 THRU 20)	
	2865001	SAW TILTING WORM ASSY. (ITEMS 13 THRU 15)	
13	3865001	WORM	1
14	3701031	SHAFT	1
15	6626031	SPRING PIN, 3/16 x 1-1/8	1
16	6420002	KEY, WOODRUFF NO. 608	1
17	3096244	LOCK SHAFT COLLAR	1
18	3065006	SAW TILT BRACKET	1
19	6715016	CUP PT. SOC. SET SCR., 5/16-18 x 5/16	2
20	6861901	FLAT WASHER, 3/4 x 1 x 1/16	2
	2271008	HANDWHEEL ASSY. (ITEMS 21 THRU 23)	2
21	6624006	GROOVE PIN, 1/4 x 3	2
22	3268201	NYLON HANDLE	2
23	3271039	8" HANDWHEEL	2
	2865002	SHAFT WORM ASSY., (ITEMS 24 THRU 26)	
24	3865001	WORM	1
25	3701032	SAW RAISING SHAFT	1
26	6626031	SPRING PIN, 3/16 x 1-1/8	1
	2695004	SCREW LOCKING ASSY. (ITEMS 27 THRU 29)	2
27	3582009	SAW RAISING LOCK PIN	2
28	6714004	CUP PT. SOC. SET SCR., 1/4-20 x 1/4	2
29	3406018	KNOB (PLATED)	2
30	2087001	DUST CHUTE ASSY. (WELDMENT)	1
31	6715033	HEX HD. CAP SCR., 5/16-18 x 1/2	1
32	6861200	LOCK WASHER, 5/16	1
33	3810018	CENTER TRUNNION	1
34	3480010	MOTOR MOUNT	1
35	3717017	ARBOR SHEAVE	1
36	3838004	ARBOR BEVEL WASHER, OUTER	1
37	3844204	SPACER WASHER, 3/8 x 7/8 x .141	6
38	3530006	SAW BLADE RETAINING NUT, 5/8-12	1
39	3096044	SHAFT COLLAR	1
40	3810023	FRONT & REAR TRUNNION	2
41	3735075	SPACER	1
42	3717018	MOTOR SHEAVE	1
	3717058	MOTOR SHEAVE, 3/4 BORE	1
	3717060	MOTOR SHEAVE, 7/8 BORE	1
43	6715144	SOC. SET SCR., 5/16-18 x 5/16	2
44	6077004	"V" BELT, 4L-230, (MATCHED SET OF 3)	3
45	3711005	SAW ARM PIVOT SHAFT	1
46	6080041	SAW BLADE, 10 COMBINATION, 5/8 BORE	1

NO.	PART NO.	DESCRIPTION	QTY.
47	6080042	REGULAR CUT-OFF SAW BLADE, 5/8 BORE	1
48	6080043	REGULAR RIP SAW BLADE, 5/8 BORE	1
49	6080044	HOLLOW GROUND PLANER BLADE. 5/8 BORE	1
50	6578003	FLEXLOC SELF LOCKING HEX NUT, 1-1/8-12	1
51	6572004	LOCK HEX NUT, 3/4-16	1
52	6716082	SQ HD SET SCR, 3/8-16 x 2-1/2	1
53	6861901	NYLATRON FLAT WASHER, 3/4	2
54	6670092	RETAINING RING, EXTERNAL NO. 5107-112	1
55	3700090	SPLITTER SUPPORT SHAFT	1
56	3690232	ADJ. SCR, 3/4-16 x 1-1/2	1
57	6572005	HEX JAM NUT, 3/4-16	1
58	6420002	KEY, WOODRUFF NO. 608	2
59	6715016	CUP PT SOC SET SCR, 5/16-18 x 5/16	2
60	6715015	CUP PT SOC SET SCR, 5/16-18 x 1/4	2
61	6718017	HEX HD CAP SCR, 1/2-13 x 1-3/4	2
62	6861500	LOCK WASHER, 1/2	2
63	6861501	FLAT WASHER, 1/2	2
67	6716079	SQ HD SET SCR, 3/8-16 x 1	1
68	6716039	HEX HD CAP SCR, 3/8-16 x 1-1/4	2
69	6716035	HEX HD SCR, 3/8-16 1-3/4	4
70	6861300	LOCK WASHER, 3/8	11
71	6861301	FLAT WASHER, 3/8	2
72	6716031	HEX HD CAP SCR, 3/8-16 x 1	6
73	6516009	HEX JAM NUT, 3/8-16	2
74	6516001	HEX NUT, 3/8-16	5
75	6472028	ELEC. MOTOR, 3 HP, 1 PH, 3600 RPM, 230V, 145 TC FRAME	1
	6471713	ELEC. MOTOR, 2 HP, 3 PH, 3600 RPM, 200V, 145 TC FRAME	1
	6471720	ELEC. MOTOR, 2 HP, 3 PH, 3600 RPM, 230/460V, 145 TC FRAME	1
	6471723	ELEC. MOTOR, 2 HP, 1 PH, 3600 RPM, 115/230V, 145 TC FRAME	1
	6472024	ELEC. MOTOR, 3 HP, 3 PH, 3600 RPM, 200V, 145 TC FRAME	1
	6472025	ELEC. MOTOR, 3 HP, 3 PH, 3600 RPM, 230/460V, 145 TC FRAME	1

FENCE ASSEMBLY

NO.	PART NO.	DESCRIPTION	QTY.
	2440001	REAR FENCE LOCK ASSY. (ITEMS 1 THRU 5)	
1	3063027	REAR FENCE MOUNTING BRACKET	1
2	3448001	REAR LOCK	1
3	6626038	SPRING PIN, 1/4 x 1	1
4	6514001	HEX NUT, 1/4-20	1
5	6714072	FLAT PT SQ HD SET SCR, 1/4-20 x 1	1
	2078001	FENCE ASSY CARRIAGE, (ITEMS 6 THRU 25)	2
	2268017	CARRIAGE FENCE HANDLE ASSY, (ITEMS 6 & 7)	
6	3670039	ZINC PLATED CAM HANDLE ROD	2
7	3406201	NYLON TEARDROP KNOB	2
	2586001	PINION ASSY., (ITEMS 8 THRU 10)	
8	3586007	FENCE CARRIAGE PINION	1
9	3406017	KNOB	1
10	6714004	CUP PT SOC SET SCR, 1/4-20 x 1/4	1
11	3064033	BRACKET	1
12	3076001	FRONT LOCK CAM	1
13	3076227	REAR LOCK CAM	1

NO.	PART NO.	DESCRIPTION	QTY.
14	3196002	CARRIAGE FENCE, TA-74	1
15	3604005	ALUM. POINTER, .051 T.A.	1
16	6706037	RD HD MACH SCR, No. 6-32 x 3/16	1
17	6626050	SPRING PIN, 3/8 x 1-3/4	2
18	6626038	SPRING PIN, 1/4 x 1	1
19	6813060	COMP. SPRING, No. 65-2, 7/16 x 1-5/16	1
20	6718090	FLAT PT SOC SET SCR, 1/2-13 x 3/4	1
21	6861100	LOCK WASHER, 1/4	1
22	6714026	FIL HD CAP SCR, 1/4-20 x 5/8	1
23	6714081	SLOT HD SET SCR, 1/4-20 x 3/8	1
24	6714087	HALF DOG PT SOC SET SCR, 1/4-20 x 1/4	1
25	6716003	CUP PT SOC SET SCR, 3/8-16 x 3/8	2
26	6626001	SPRING PIN, 1/8 x 5/8	1
27	3670058	LOCK PIN	1
28	6813068	COMP. SPRING, 9/16 x 2	1
29	6680019	RIVET, .188 x 1/2 x 3/8	1
30	3196004	FENCE	1
31	6716012	SOC HD CAP SCR, 3/8-16 1	1
32	6715020	SOC HD CAP SCR, 5/16-18 x 1	2

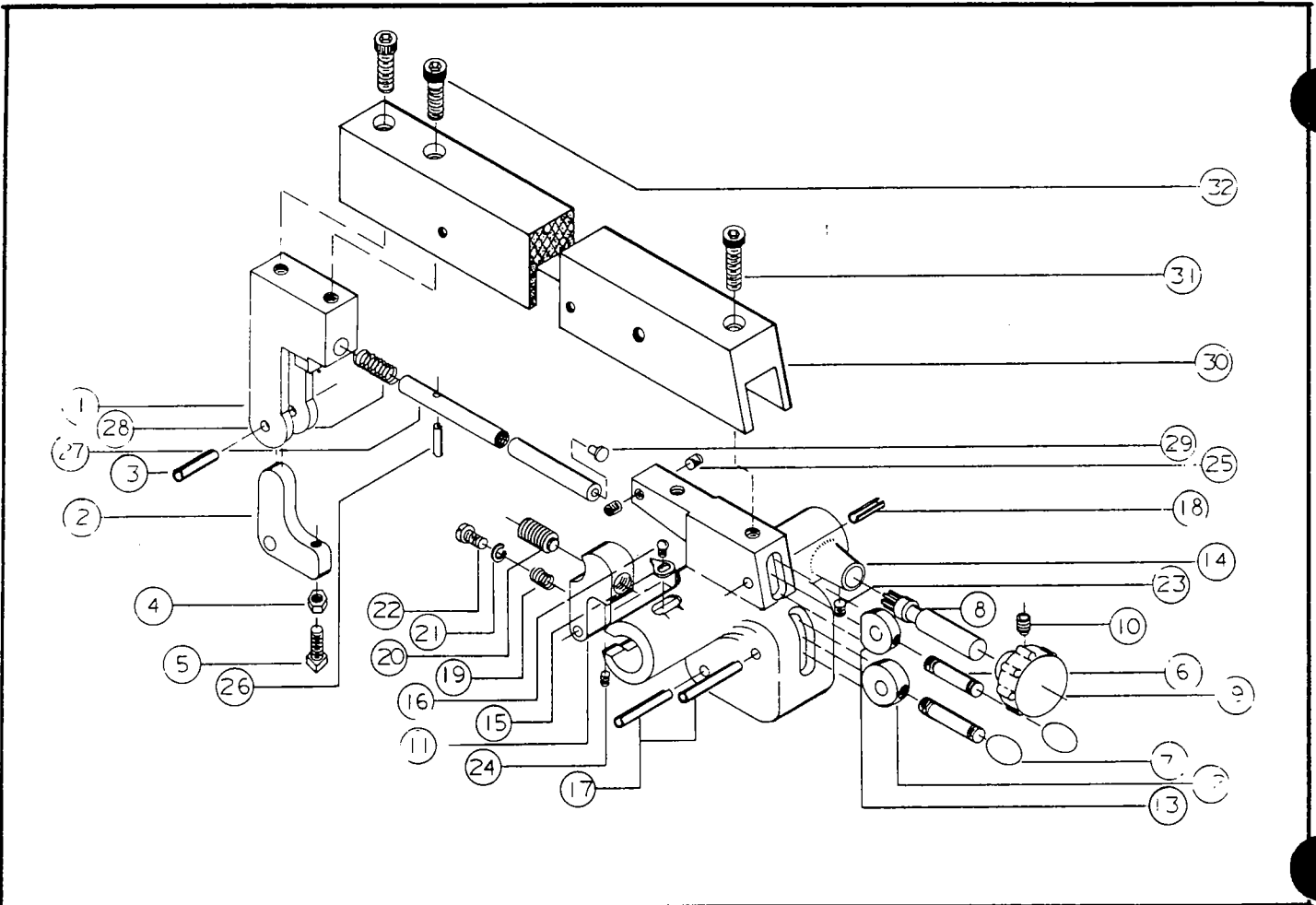

MITER GAGE & ROD STOP ASSEMBLY

NO.	PART NO.	DESCRIPTION	QTY.
	2471009	MITER GAGE ASSY, (ITEMS 1 THRU 13)	
1	3268050	MITER KNOB	1
2	6861101	FLAT WASHER, 1/4	1
3	6706041	RD HD MACH SCR, No. 6-32 x 3/4	2
4	6506003	HEX NUT, No. 6-32 (PLATED)	3
5	6706094	RD HD MACH SCR, No. 6-32 x 1/2	3
6	3582097	STOP PIN	1
7	3055101	POINTER BLOCK	1
8	3044313	MITER GAGE BAR	1
9	3695220	LOCK SCREW	1
10	6623012	DOWEL PIN, 1/4 x 1	1

NO.	PART NO.	DESCRIPTION	QTY.
11	6714053	FLAT HD MACH SCR, 1/4-20 x 3/8	1
12	3841202	MITER GAGE RETAINING WASHER	1
13	3230007	MITER GAGE	1
	2670003	STOP ROD ASSY, (ITEMS 14 THRU 18)	
14	6510002	WING NUT, No. 10-24	2
15	3092001	CLAMP	4
16	3670003	STOP ROD (STRAIGHT)	1
17	3670002	STOP ROD	1
18	6086000	CARRIAGE BOLT, No. 10-24 x 3/4	2
19	6714080	THUMB SCR, 1/4-20 x 1/2	2

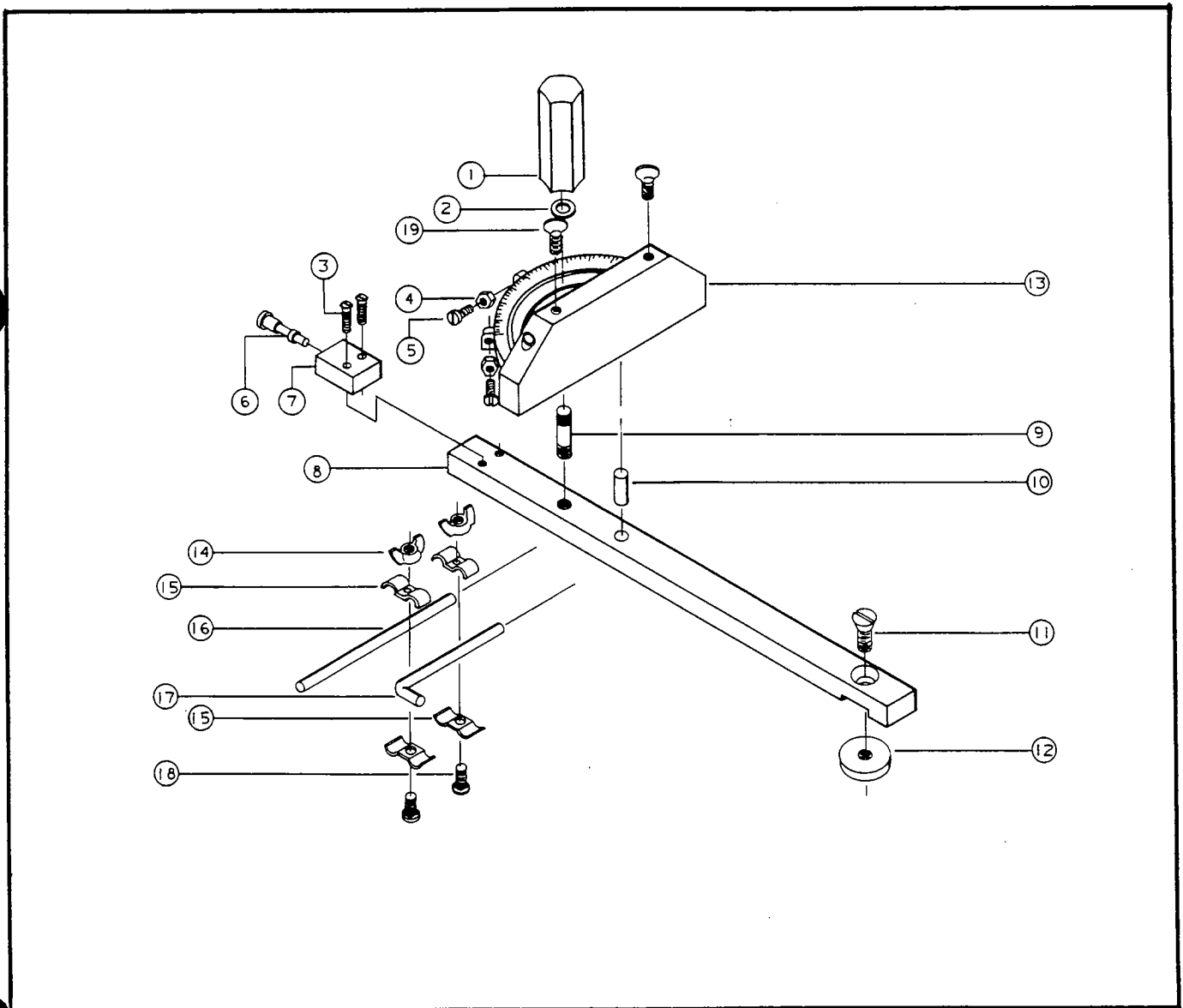

OVERHANGING GUARD ASSEMBLY PARTS

NO.	PART NO.	DESCRIPTION	QTY.
	2250117	OVERHANGING GUARD ASSY, (ITEMS 1 THRU 25)	
1	6680009	FL HD RIVET, 5/16 x 7/8	2
2	6680005	FL HD RIVET, 1/4 x 7/8	2
3	3046202	PIVOT SPACER BEARING	2
4	3250113	BLADE GUARD, R. H.	1
5	3064072	TUBE HOLDING BRACKET	1
6	3025036	PIVOT GUARD ARM, R. H.	1
7	3096003	COLLAR	4
8	6715133	THUMB SCREW, 5/16-18 x 1	4
9	3816011	MOUNTING TUBE	1
10	6514001	HEX NUT, 1/4-20	2
11	6514012	FLEX-LOC NUT, 1/4-20	1
12	6714063	RD HD MACH SCR, 1/4-20 1/2	2
13	3791001	TUBE SUPPORT	1
14	3750011	SPLITTER	1
15	6861101	FLAT WASHER, 1/4	4
16	6714131	HEX HD CAP SCR, 1/4-20 x 5/8	1
17	3581006	ANTI-KICKBACK PAWL	2

NO.	PART NO.	DESCRIPTION	QTY.
18	3025037	PIVOT GUARD ARM, L. H.	1
19	3250114	BLADE GUARD, L. H.	1
20	6706038	RD HD MACH SCR, No. 6-32 x 1/2	3
21	3595061	SAFETY PLATE	1
22	6626002	SPRING PIN, 1/8 x 3/8	2
	2695003	LOCK ASSY SCREW (ITEMS 23 THRU 25)	
23	3406016	HANDLE KNOB	1
24	3695001	LOCK SCREW	1
25	3268002	HANDLE	1
	2787008	SPLITTER REAR SUPPORT ASSY, (ITEMS 26 THRU 32)	
26	2406001	KNOB ASSY	1
27	3690232	ADJUST SCREW, 3/4-16 x 1-1/2	1
28	6572005	HEX JAM NUT, 3/4-16	1
29	3776050	REAR SPLITTER SUPPORT	1
30	6861200	LOCK WASHER, 5/16	3
31	6715034	HEX HD CAP SCR, 5/16-18 x 1-1/4	3
32	3700090	SPLITTER SUPPORT SHAFT	1

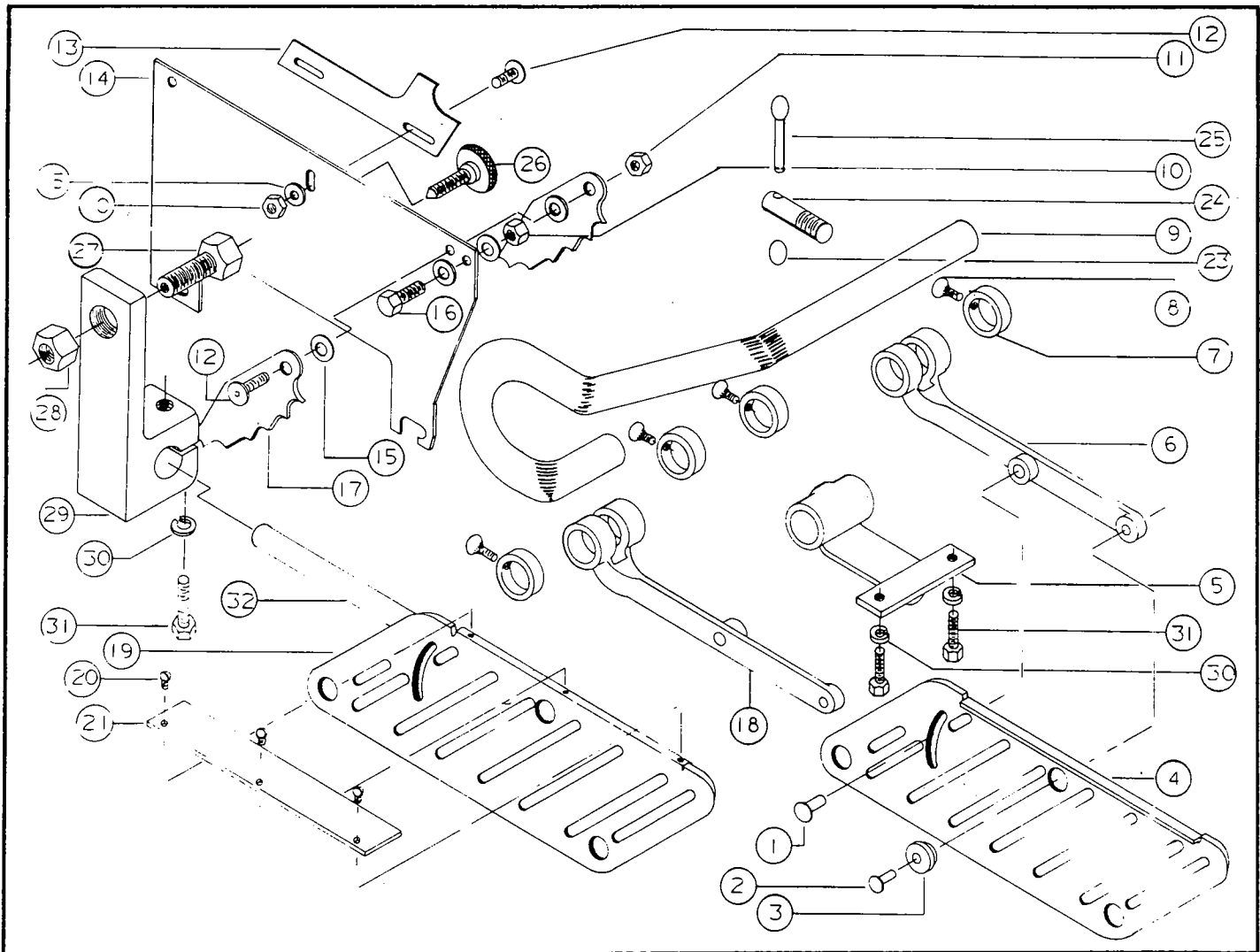

OLD OVERHANGING GUARD ASSEMBLY PARTS

NO.	PART NO.	DESCRIPTION	QTY.
	2787008	SPLITTER REAR SUPPORT ASSY, (ITEMS 1 THRU 7)	
1	2406001	KNOB ASSY	1
2	3690232	ADJ SCREW, 3/4-16 x 1-1/2	1
3	6572005	HEX JAM NUT, 3/4-16	1
4	3776050	REAR SPLITTER SUPPORT	1
5	6861200	LOCK WASHER, 5/16	1
6	6715034	HEX HD CAP SCR, 5/16-18 x 1-1/4	1
7	3700090	SPLITTER SUPPORT SHAFT	1
	2250003	OVERHANGING GUARD ASSY, (ITEMS 8 THRU 34)	
	2750001	SPLITTER ASSY, (ITEMS 8 THRU 12)	
8	3581002	ANTI-KICKBACK PAWL	2
9	3750006	SPLITTER	1
10	6626028	SPRING PIN, 3/16 x 1/2	1
11	6714127	HEX HD CAP SCR, 1/4-20 x 1/2	1
12	6514011	HEX JAM NUT, 1/4-20	1
	2695003	LOCK SCREW ASSY, (ITEMS 13 THRU 15)	
13	3268002	HANDLE	1
14	3695001	LOCK SCREW	1

NO.	PART NO.	DESCRIPTION	QTY.
15	3406016	KNOB	1
16	6714083	BUTTON HD SOC CAP SCR, 1/4-20 x 1/2	2
17	3816011	MOUNTING TUBE	1
18	6715133	THUMB SCR, 5/16-18 x 1	4
19	3096003	COLLAR	4
20	3025036	PIVOT GUARD ARM, R. H.	1
21	3064072	TUBE HOLDING BRACKET	1
22	3025037	PIVOT GUARD ARM, L.H.	1
23	3250055	LEAF GUARD, R. H.	1
24	3046202	PIVOT SPACER BEARING	2
25	6680005	FLAT HD RIVET, 1/4 x 7/8	2
26	6680009	FLAT HD RIVET, 5/16 x 7/8	2
27	3595061	SAFETY PLATE	1
28	6706038	RD HD MACH SCR, No. 6-32 x 1/2	3
29	3250328	GUARD, L. H.	1
30	3791001	TUBE SUPPORT	1
31	6514011	HEX JAM NUT, 1/2-20	2
32	6861300	LOCK WASHER, 3/8	2
33	6716031	HEX HD CAP SCR, 3/8-16 x 1	2
34	6861102	PLAIN THIN FLAT WASHER, 1/4-20	2

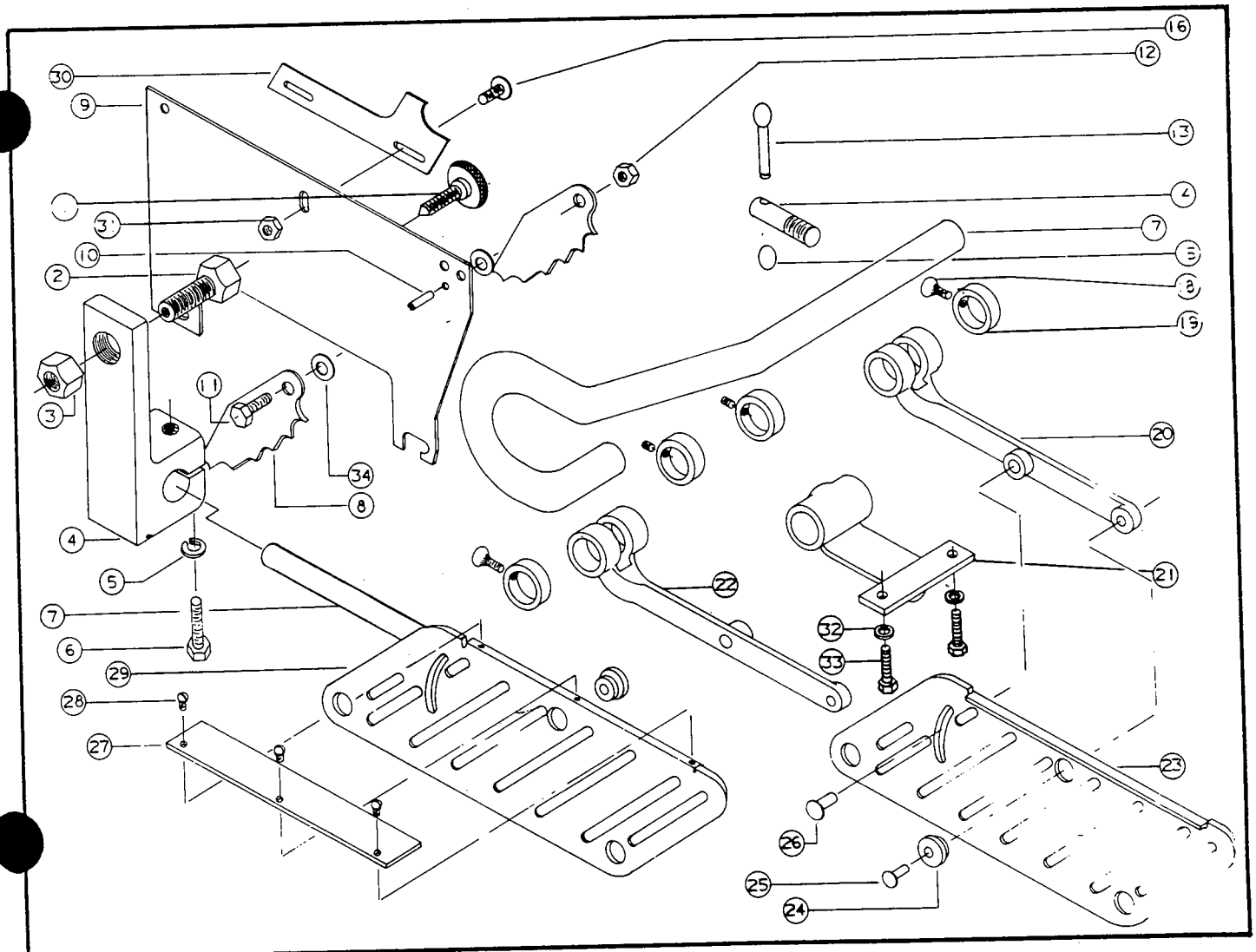

SPLITTER AND GUARD ASSEMBLY PARTS

NO.	PART NO.	DESCRIPTION	QTY.
	2787008	SPLITTER REAR SUPPORT ASSY, (ITEMS 1 THRU 7)	
1	6715034	HEX HD CAP SCR, 5/16-18 x 1-1/4	1
2	6861200	LOCK WASHER, 5/16	1
3	3776050	SPLITTER REAR SUPPORT	1
4	6572005	HEX JAM NUT, 3/4-16	1
5	3690232	ADJUST SCR, 3/4-16 x 1-1/2	1
6	2406001	KNOB ASSY	1
7	3700090	SPLITTER SUPPORT SHAFT	1
	2250116	GUARD AND SPLITTER ASSY, (ITEMS 8 THRU 28)	
8	6861101	FLAT WASHER, 1/4	2
9	6714158	HEX HD CAP SCR, 1/4-20 x 5/8	1
10	6714192	FL HD SOC SCR, 1/4-20 x 7/8	10
11	3250112	BLADE GUARD	2
12	3838015	PIVOT WASHER	4

NO.	PART NO.	DESCRIPTION	QTY.
13	6514012	LOCK NUT, 1/4-20	9
14	6626029	SPRING PIN, 3/16 x 1	1
15	6626050	SPRING PIN, 3/8 x 1-3/4	1
16	3720018	GUARD SHIELD	1
17	6710032	RD HD MACH SCR, No. 10-24 x 1/4	2
18	3720017	FRONT SHIELD	1
19	6714053	FL HD MACH SCR, No. 10-24 x 3/8	2
20	3055095	PIVOT BLOCK	1
21	3025074	PIVOT ARM	4
22	3070108	PIVOT BUSHING	8
23	6514001	HEX NUT, 1/4-20	2
24	3581006	ANTI-KICKBACK PAWL	2
25	3044307	SPLITTER BAR	1
26	3750011	SPLITTER	1
27	3735203	SPACER	2
28	3837206	WASHER	5

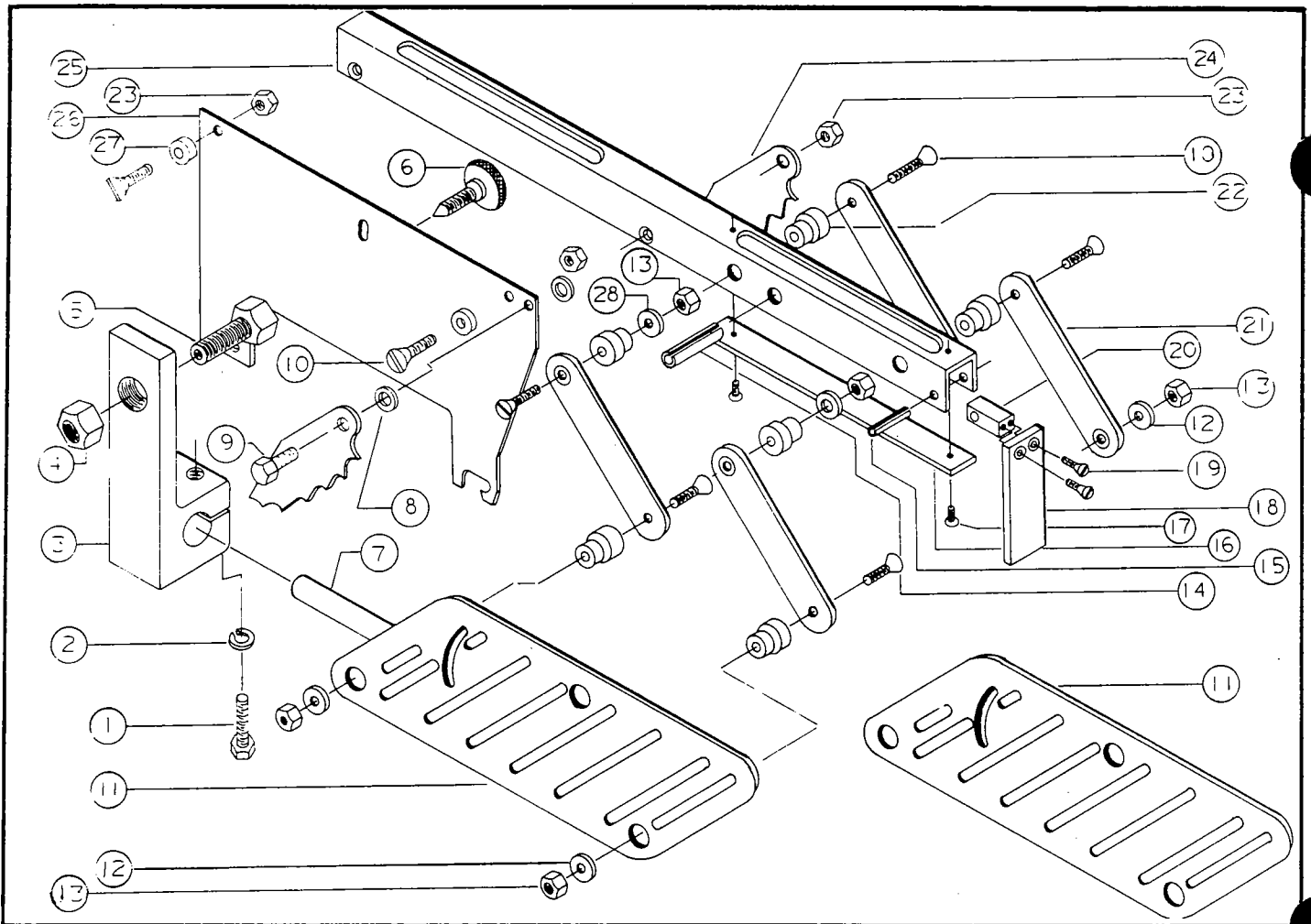

OLD SPLITTER & GUARD ASSEMBLY PARTS

NO.	PART NO.	DESCRIPTION	QTY.
	2787008	SPLITTER REAR SUPPORT ASSY, (ITEMS 1 THRU 7)	
1	2406001	KNOB ASSY	1
2	3690232	ADJ SCREW, 3/4-16 x 1-1/2	1
3	6572005	HEX JAM NUT, 3/4-16	1
4	3776050	SPLITTER SUPPORT, REAR	1
5	6861200	LOCK WASHER, 5/16	1
6	6715034	HEX HD CAP SCR, 5/16-18 x 1-1/4	1
7	3700090	SPLITTER SUPPORT SHAFT	1
	2250002	BLADE & SPLITTER GUARD ASSY, (ITEMS 8 THRU 25)	
	2025001	PIVOT ARM ASSY, (ITEMS 8 THRU 10)	4
8	3046201	BEARING	4
9	3584216	PIVOT PIN	4
10	3025004	ALUMINUM ARM	2
	2750001	SPLITTER ASSY, (ITEMS 11 THRU 15)	

NO.	PART NO.	DESCRIPTION	QTY.
11	3581002	ANTI-KICKBACK PAWL	2
12	3750006	SPLITTER	1
13	6626028	SPRING PIN, 3/16 x 1/2	1
14	6714127	HEX HD CAP SCR, 1/4-20 x 1/2	1
15	6514011	HEX JAM NUT, 1/4-2	1
16	3250056	LEAF GUARD, L. H.	1
17	3250055	LEAF GUARD, R. H.	1
18	3025041	SUPPORT ARM	1
19	3584217	PIVOT PIN	2
20	6626050	SPRING PIN, 3/8 x 1-3/4	1
21	6670097	RETAINING RING, TRUARC NO. 5144-37	8
22	6414060	HEX SOC CAP FLAT HD SCR, 1/4-20 x 1	2
23	6514005	HEX NUT, 1/4-20	2
24	3735203	BEARING SPACER	2
25	6861102	PLAIN THIN FLAT WASHER, 1/4-20	2

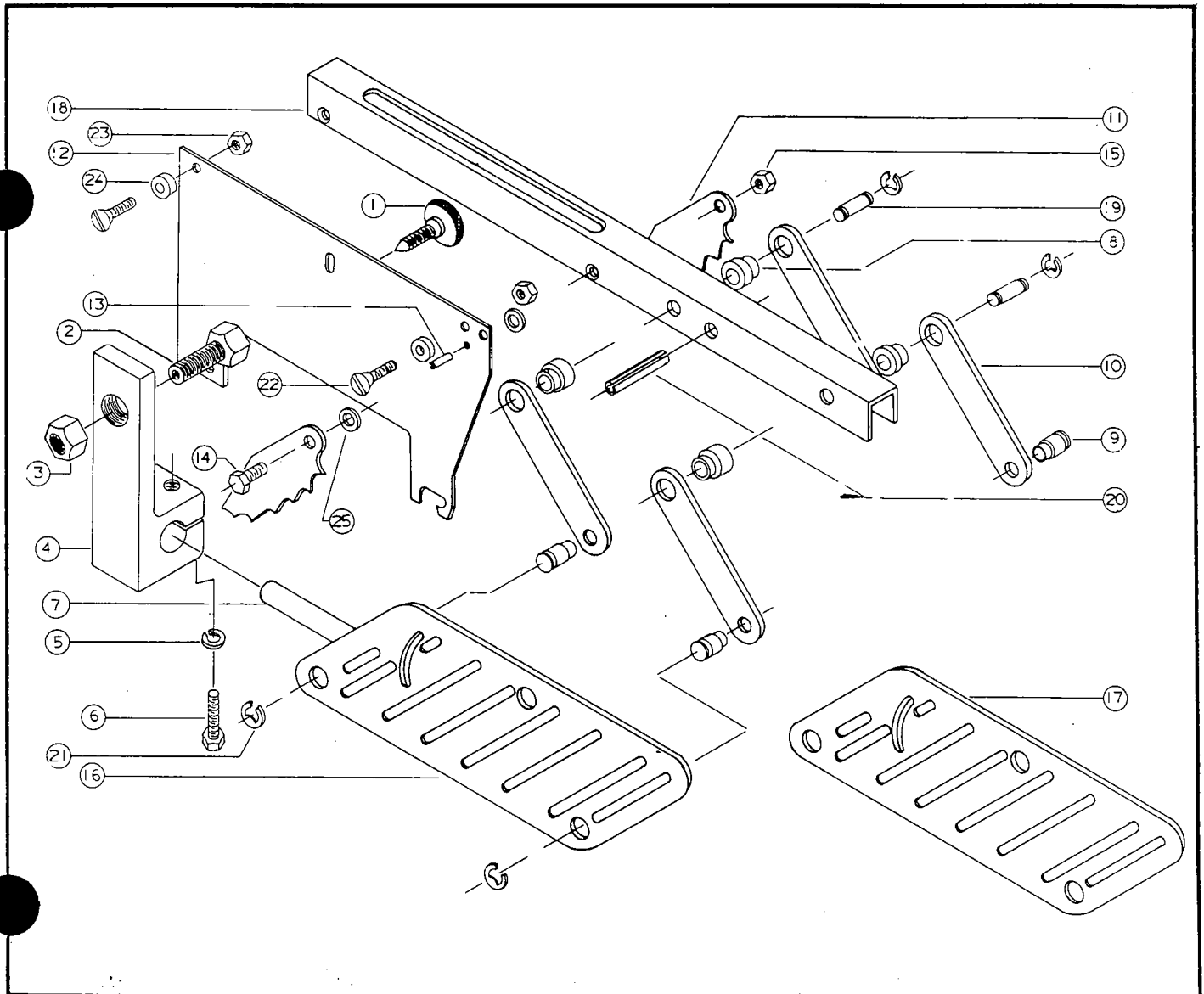

ELECTRICAL SCHEMATIC

MANUAL

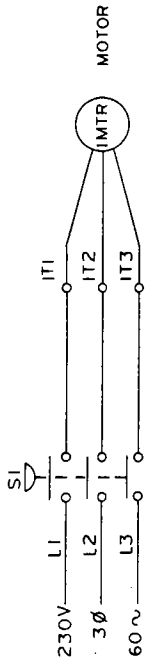

REF.	QTY.	POWERMATIC NO	MFG. DESCRIPTION
S1	(3Ø)	6821135	SWITCH FURNAS 12 BA34P
	(1Ø)	6821134	SWITCH FURNAS 12 BA24P

MAGNETIC

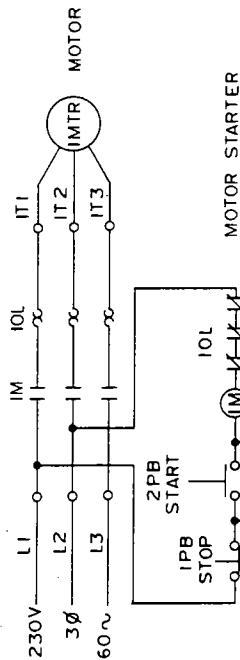

REF.	QTY.	POWERMATIC NO	MFG. DESCRIPTION
M1	(3Ø)	6816113	STARTER, MAGNETIC, FURNAS, 14DF32BC71
	(1Ø)	6816106	STARTER, MAGNETIC, FURNAS, 14DF12BA7
	(PBI)	6821200	SWITCH FURNAS MOMENTARY PB 50D54688

MAGNETIC WITH LOW VOLTAGE CONTROL

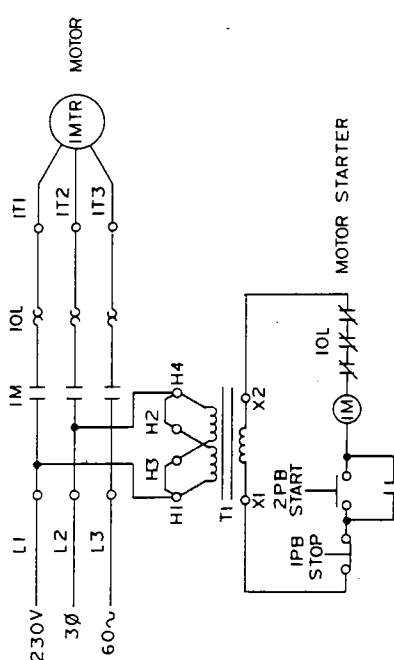

REF.	QTY.	POWERMATIC NO	MFG. DESCRIPTION
(PBI)	(PBI)	6821200	SWITCH FURNAS MOMENTARY PB 50D54688
T1		6831068	TRANSFORMER, 115/230-24V, 50VA
		6831069	" 230/460-24V, 75VA
		6831070	" 230/460-115V, 50VA
IM		6816120	STARTER, MAG., VVXMR, 1Ø, 24V, FURNAS, 14DF107014
		6816139	" " " 1Ø, 115V, FURNAS, 14DF10708
		6816124	" " " 3Ø, 24V, FURNAS, 14DF32BJ71BD
		6816128	" " " 3Ø, 115V, FURNAS, 14DF32BA71BA
		6471723	MOTOR, ELEC., 2HP, 1Ø, 3600 RPM, 115/230V, 145 FR
		6472024	" " " 3HP, 3Ø, 3600 RPM, 200V, 145 FR
		6472025	" " " 3HP, 3Ø, 3600 RPM, 230/460V, 145 FR
		6472028	" " " 3HP, 1Ø, 3600 RPM, 230V, 145 FR
		6472307	" " " 5HP, 3Ø, 3600 RPM, 230 460V, 1Ø4C FR
		6472327	" " " 5HP, 3Ø, 3600 RPM, 200V, 1Ø4C FR
		6472511	" " " 7½HP, 3Ø, 3600 RPM, 200V, 1Ø4C FR
		6472504	" " " 7½HP, 3Ø, 3600 RPM, 230/460V, 1Ø4C FR

NOTE:
FOR SINGLE PHASE UNITS,
OMIT LINE L3

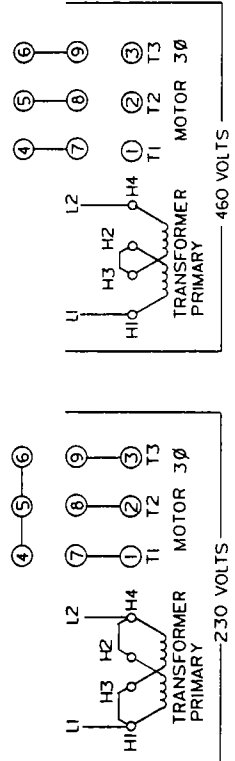

POWERMATIC  **LOUDAILLE, INC.**

McMinnville, Tennessee 37110